

About

Alcune opere d'arte, soprattutto nelle culture tribali, si rifanno alla natura e ai suoi abitanti. KRAN, è un'antica scultura la cui forma ha ispirato questo corpo illuminante, così protagonista e fiero; una composizione fantastica e surreale i cui occhi sembrano voler catturare l'attenzione dei presenti.

M

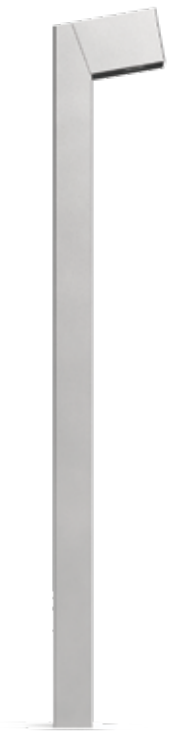

Inox Natural



Inox Graphite

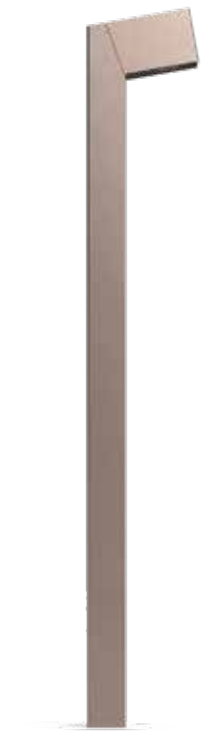

Inox Bronze

01



M



Inox Natural



Inox Graphite

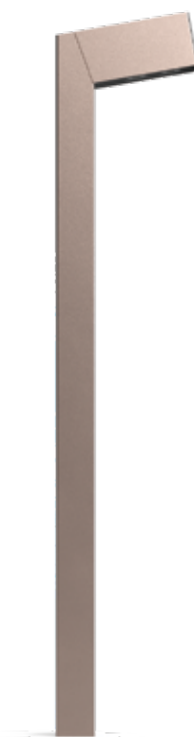

Inox Bronze

02



M



Inox Natural



Inox Graphite

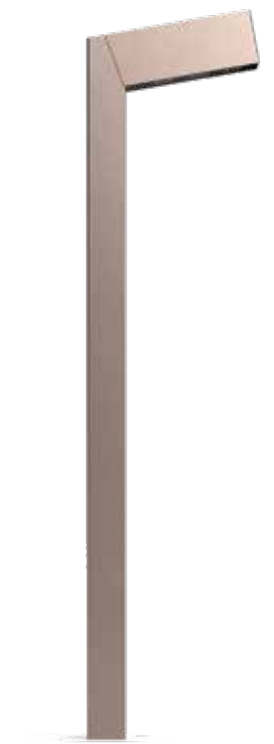

Inox Bronze

03



EN Bollard available with height 60 cm and 90 cm made of AISI 316L stainless steel. Pole top in versions with one, two or three LEDs for different design needs. 21°, 45° and 65° optics at 2700K, 3000K and 4000K Flush black silk-screened glass extra-clear tempered, 4 mm thick. Integrated power supply. Flange with anchor bolts for installation in concrete. HCT surface finish available in three variants.

ITA Paletto disponibile con altezza 60 cm e 90 cm realizzato in acciaio inox AISI 316L. Testa palo nelle versioni con uno, due o tre LED per le diverse esigenze progettuali. Ottiche da 21°, 45° e 65° da 2700K, 3000K e 4000K. Vetro a filo serigrafato nero, temperato extra-chiaro di spessore 4 mm. Alimentatore integrato. Flangia con tirafondi per installazione nel cemento. Finitura superficiale HCT disponibile in tre varianti.

FR Borne disponible en deux hauteurs de 60 et 90 cm, en acier inox AISI 316L. Tête de poteau dans les versions avec une, deux ou trois LED, selon les exigences de conception. Optiques de 21°, 45° et 65° à 2700K, 3000K et 4000K. Verre affleurant sérigraphié noir, trempé extra-clair de 4 mm d'épaisseur. Alimentation intégrée. Bride avec tirefonds pour installation dans le béton. Finition de surface HCT disponible en trois variantes.

DE Poller verfügbar mit Höhe 60 cm und 90 cm aus Edelstahl AISI 316L. Mastaufsatz in Versionen mit einer, zwei oder drei LEDs für unterschiedliche Designansprüche. Optiken von 21°, 45° und 65° von 2700K, 3000K und 4000K. Bündiges, extra klares gehärtetes schwarzes Siebdruckglas 4 mm dick. Integriertes Netzteil. Flansch mit Schwelenschrauben zum Einbau in Beton. HCT-Oberflächenbearbeitung in drei Ausführungen erhältlich.

KRAN M01

Color			Emission
2700 K 543 lm	3000 K 550 lm	4000 K 613 lm	
Power 5 W			
Codes Technical details			

IP66 IK08 Accessories p. 238

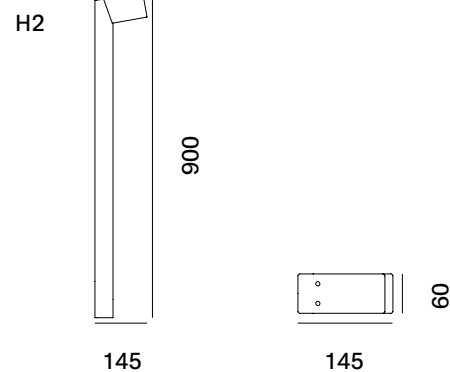
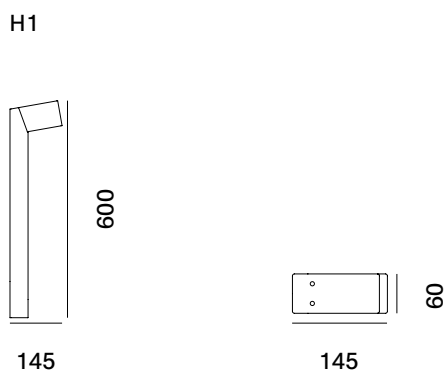

KRAN M02

Color			Emission
2700 K 1087 lm	3000 K 1100 lm	4000 K 1227 lm	
Power 10 W			
Codes Technical details			

IP66 IK08 Accessories p. 238

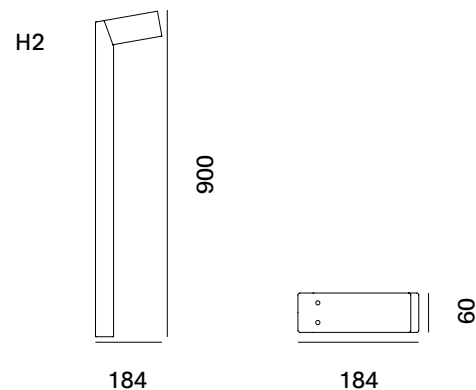
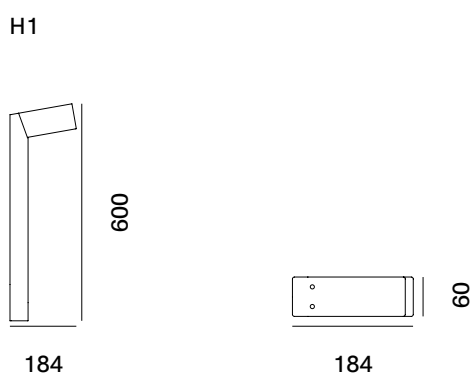

Color

2700 K
1630 lm

3000 K
1650 lm

4000 K
1840 lm

Emission



21°



45°



65°

Power
15 W



Codes
Technical details

IP66 IK08 Accessories p. 238

H1

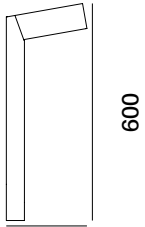

600

223



60

223

H2



900

223



60

223

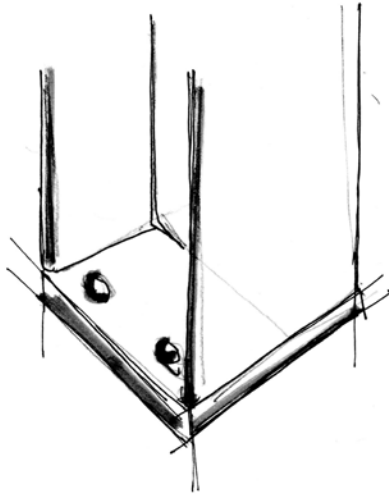
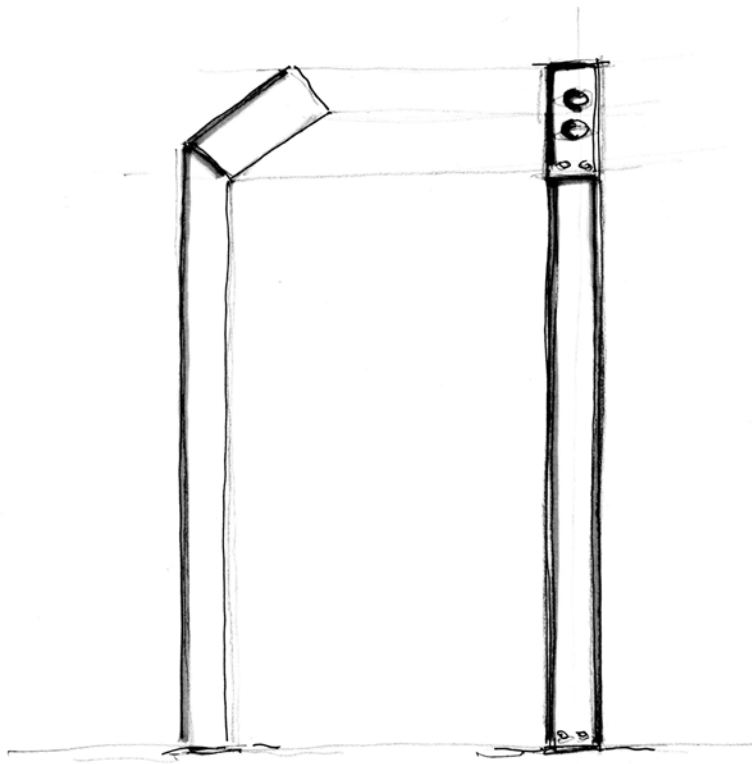



Translations

EN Some artworks, especially in tribal cultures, refer to nature and its inhabitants. KRAN, is an ancient sculpture whose shape has inspired this lighting fixture, so protagonist and proud; a fantastic and surreal composition whose eyes seem wanting to capture the attention of those present.

FR Certaines œuvres d'art, en particulier dans les cultures tribales, font référence à la nature et à ses habitants. KRAN est inspiré d'une sculpture antique dont la forme a inspiré ce corps lumineux, à la fois protagoniste et fier. C'est une composition fantastique et surréaliste dont les yeux semblent vouloir capter l'attention des personnes présentes.

DE Einige Kunstwerke, insbesondere in Stammeskulturen, beziehen sich auf die Natur und ihre Bewohner. KRAN ist eine antike Skulptur, deren Form diesen Leuchtkörper inspiriert hat, als Hauptfigur und stolz; eine fantastische und surreale Komposition, deren Augen die Aufmerksamkeit der Anwesenden auf sich ziehen wollen.